



DS & DSN DECONNECTORS

INSDS/DSN 072408 E



Meltric Corporation
4640 Ironwood Drive
Franklin, WI 53132
(800)433-7642
www.meltric.com

GENERAL

DS and DSN Deconnector™ Series products are designed to provide the safety and functionality of a switch with the convenience of a plug & receptacle. They can safely be used to make and break electrical connections, even in overload situations and are an approved 'line of sight' disconnect switch. Please follow the instructions below to ensure the proper installation and use of the product.

RATINGS

Meltric's Deconnector™ Series Switch Rated plugs & receptacles are UL & CSA listed in accordance with UL Subject 2682, UL 1682 and CSA 22.2 182.1. All are listed as 'Branch Circuit Disconnect Switches' and most are also horsepower rated and listed as 'Motor Circuit Disconnect Switches'. The amperage, voltage, horsepower, switch and environmental ratings are indicated on the product labels.

All Deconnectors are rated to make and withstand short circuit currents of 65kA or more. These ratings are indicated in Table 1 along with the fusing upon which they are based.

Device	Rating Fuse	Type*
DSN20 - 20A	100 kA @ 480 VAC	RK1 35A
DSN30 - 30A	100 kA @ 600 VAC	RK1 125A
DSN60 - 60A	100 kA @ 600 VAC	RK1 110A
DS100 - 20A	100 kA @ 600 VAC	RK1 80A
DS30 - 30A	100 kA @ 600 VAC	RK1 125A
DS60 - 60A	100 kA @ 600 VAC	RK1 250A
DS100C - 100A	100 kA @ 600 VAC	RK1 250A
DS100 - 100A	65 kA @ 600 VAC	RK5 100A
DS200 - 200A	65 kA @ 600 VAC	RK5 200A

* Rating applies with fusing up to this amperage. Ratings are based on tests performed with Ferraz Shawmut non-time delay current limiting fuses.

INSTALLATION

Deconnectors should be installed by qualified electricians in accordance with all applicable local and national electrical codes. Before starting, verify that

the power is off, that the power ratings are appropriate for the application, and that the conductors meet code requirements and are within the capacities of the terminals noted in Table 2.

Device	Main Contacts		Aux. Contacts ²
	Minimum	Maximum	Maximum
DSN20 - 20A	20	12	n/a
DSN30 - 30A	14	8	8
DSN60 - 60A	12	4	12
DS20 - 20A	14	8	8
DS30 - 30A	12	4	12
DS60 - 60A	6	2	14 ³
DS100C - 100A	6	2	14 ³
DS100 - 100A	4	2/0	14 ³
DS200 - 200A	4	3/0 ⁴	14 ³

¹ Capacity is based on THHN wire sizes

² Auxiliary contacts are optional and may not be on all products.

³ Auxiliary contacts are prewired at the factory.

⁴ 4/0 AWG if part number includes the 'A06' suffix.

General Notes & Precautions

- Self-tapping screws are provided for use with some polymeric accessories. High torque may be required to drive them in. Once they are seated, care should be taken in order to avoid over-tightening them against the plastic material.
- Various handles and cord grip options may be used. These instructions are based on handles provided with integral multi-layer bushing cord grips.
- Wire strip lengths are indicated in Table 3. Strip lengths for cable sheathing will depend on the specific application. When used with handles, the cable sheathing should extend into the handle to ensure secure cord gripping.



Device	Receptacle		Plug/Inlet	
	Inches	mm	Inches	mm
DSN20 Phase	1/2	13	5/8	16
DSN30 Phase	7/16	10	3/4	19
DSN30 Auxil.	1/2	12	3/4	19
DSN60 Phase	9/16	14	7/8	22
DSN60 Auxil.	1/2	13	5/8	16
DS20 Phase	7/16	10	3/4	19
DS20 Auxil.	1/2	12	3/4	19
DS30 Phase	9/16	14	7/8	22
DS30 Auxil.	1/2	13	5/8	16
DS60 Phase	15/16	24	15/16	24
DS100C Phase	15/16	24	15/16	24
DS100 Phase	1 3/16	30	1 3/16	30
DS200 Phase	1 3/16	30	1 3/16	30

- Wiring terminals are spring assisted to prevent loosening due to stand settlement, vibration and thermal cycling. They should not be over-tightened. Appropriate tools and tightening torques are indicated in Table 4.

Device/Contact	Torque		Required Screwdriver or Allen Wrench
	in-lbs	N-m	
DSN20 Phase	7	0.8	3 mm or 1/8" precision tip
DSN30 Phase	13	1.5	4 mm or 3/16" precision tip
DSN30 Auxil.	13	1.5	4 mm or 3/16" precision tip
DSN60 Phase	16	1.8	5 mm or 3/16" precision tip
DSN60 Auxil.	7	.8	3 mm or 1/8" precision tip
DS20 Phase	13	1.5	4 mm or 3/16" precision tip
DS20 Auxil.	13	1.5	4 mm or 3/16" precision tip
DS30 Phase	16	1.8	5 mm or 3/16" precision tip
DS30 Auxil.	7	0.8	3 mm or 1/8" precision tip
DS60 Phase	35	4.0	4 mm hex head
DS100C Phase	35	4.0	4 mm hex head
DS100 Phase	80	9.0	4 mm hex head
DS200 Phase	130	15.0	5 mm hex head

- The DS9 and DS2 are rated as general purpose switches, but are not horsepower rated. If these devices are installed in motor power supply applications, warning labels may be required to advise users not to disconnect the device under load. Labels are provided in the package, but should only be used when required.

Assembly for In-Line Connections

When Deconnectors are used as in-line connectors, finger drawplates (or a drawbar mechanism for the DS9 & DS2) should be installed on both the receptacle and plug in order for the user to more easily provide the leverage required to connect the device.

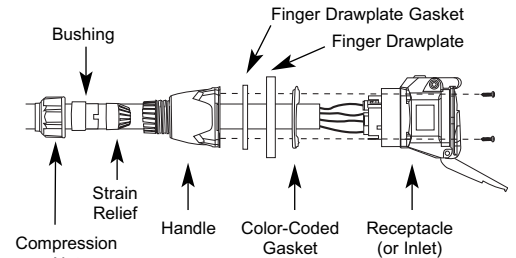

Adjust the bushing diameter to fit the cable by removing inner sections of it as required. Insert the bushing into the strain relief, then insert the assembly into the handle and loosely install the compression nut. Insert the cable through the handle, the thin black drawplate gasket and finger drawplate (if applicable) and the color coded gasket. Strip the cable sheath to provide a workable wire length, being mindful that the sheath must extend into the handle to achieve a secure cord grip. Then strip the individual wires to the lengths indicated in Table 3 and twist the strands of each conductor together.

Back out the terminal screws on the receptacle (or inlet) far enough (but not completely) to allow the conductors to pass, insert the conductors fully into their respective terminals and tighten the terminal screws with the appropriate tool to the torque indicated in Table 4.

Verify that the cable sheath extends beyond the strain relief and into the handle. Assemble the receptacle (or inlet), the color coded gasket, the finger drawplate, and the thin black drawplate gasket to the handle with the four self-tapping screws provided. Adjust the cable location so that it will not be under tension inside the handle and tighten the compression nut to secure the cable.

Assembly for Mounted Receptacles (or Inlets)

In applications where DS or DSN receptacles (or inlets) are mounted to wall boxes, panels or other equipment, optimal operation is achieved when the device is installed with the latch at the top.

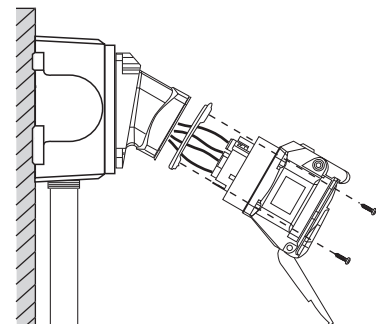

Insert the cable or wires through the wall box and cut to allow adequate length, strip the cable sheath as desired, strip the individual wires to the lengths indicated in Table 3, and twist the strands of each conductor together. Back out the terminal screws on the receptacle (or inlet) far enough (but not completely) to allow the conductors to pass, insert the conductors fully into their respective terminals and hand tighten the terminal screws to the torque indicated in Table 4.

Assemble the receptacle (or inlet) and the color-coded gasket to the box with the appropriate hardware. Assemble the mating plug (or receptacle) to the cord end as indicated in the assembly instructions above for in-line connections, except there will be no finger drawplate or associated black gasket.

Hole Pattern for Custom Mounting

In applications where custom mounting to a panel or box is being performed, the clearance and mounting holes should be drilled as indicated in the following diagram and Table 5.

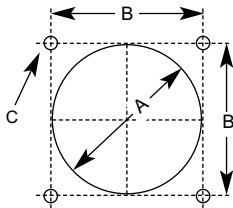

Model	'A'		'B'		C	
	Inches	mm	Inches	mm	Inches	mm
DSN20-Recept	2.00	51	1.65	42	.19	5
DSN30	2.25	57	1.89	48	.19	5
DSN60	2.50	64	2.17	55	.19	5
DS20	2.25	57	1.89	48	.19	5
DS30	2.50	64	2.17	55	.19	5
DS60 & DS100C	3.25	83	2.59	66	.22	5.5
DS100	4.00	102	3.20	81	.22	5.5
DS200	4.50	114	3.86	98	.28	7

In order to maintain the NEMA 4X or IP 66 & 67 protection provided by DSN models in custom installations, watertight seals should be used under the heads of the four mounting bolts and they must be retained by a lock washer and nut on the inside of the box or panel. Alternatively, four blind holes may be drilled and threaded to accommodate the mounting screws, provided that the hole depth is sufficient to achieve adequate gasket compression.

OPERATION

To ensure safe and reliable operation Meltric plugs and receptacles must be used in accordance with their assigned ratings. They can only be used in conjunction with mating receptacles or plugs manufactured by Meltric or another licensed producer of products bearing the **Milarecha**™ Quality Label.

Meltric plugs & receptacles are designed with different keying arrangements, so that only plugs and receptacles with compatible contact configurations and electrical ratings will mate with each other.

Connection

To connect a plug and receptacle, first depress the pawl to open the lid on the receptacle, then orient the plug as shown in figure 1 so that the red dot on the outside of the casing lines up with the red dot just to the left of the latch on the receptacle casing. Push the plug partially into the receptacle until it hits a stop, then rotate the plug in the clockwise direction until it hits another stop after about 30° of rotation. At this point, the circuit is still open. Push the plug straight into the receptacle as shown in figure 2 until

it becomes securely latched in place. The electrical connection is now made. On in-line connectors, squeeze the drawplates on both sides of the device together until the plug latches in place.

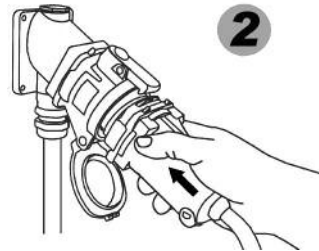
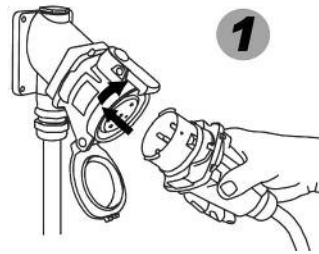

Disconnection

To break the connection, simply depress the pawl as shown in figure 3. This will break the circuit and eject the plug straight out to the rest, or off, position. The plug contacts are de-energized at this point. To remove the plug, rotate it counter-clockwise (about 30°) until it releases from the receptacle as shown in figure 4. Close and latch the lid on the receptacle.

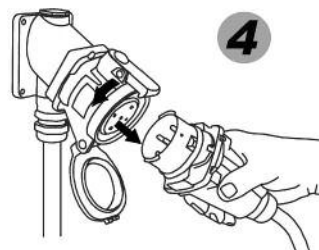
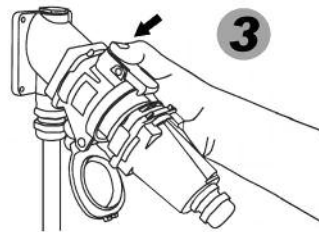

Achieving Rated Watertightness

Rated ingress protection applies to the device when the plug and receptacle are mated and latched together. It also applies to the receptacle when the lid is latched closed.

Lockout Provisions

All DS and DSN plugs are provided with lockout provisions. To lockout the plug, insert a locking device through the hole provided in the casing. This will prevent the plug from being inserted into a receptacle.

DS and DSN receptacles may be purchased with optional lockout provisions. To lockout the receptacle, close and latch the lid and then attach the locking device through the hole provided in the pawl. This will prevent the lid from being opened for the insertion of a plug.

NOTE: Attaching the receptacle locking device with the receptacle lid open will not prevent the insertion of a plug. Lockout of the receptacle is only accomplished when the lid is locked closed.

MAINTENANCE

Meltric products require little on-going maintenance. However, it is a good practice to periodically perform the following general inspections:

- Check the mounting screws for tightness.
- Verify that the weight of the cable is supported by the strain relief mechanism and not by the terminal connections.
- Check the IP gaskets for wear and resiliency. Replace as required.
- Verify the electrical continuity of the ground circuit.
- Check the contact surfaces for cleanliness and pitting.

Deposits of dust or similar foreign materials can be rubbed off the contacts with a clean cloth. Sprays should not be used, as they tend to collect dirt. If any significant pitting of the contacts or other serious damage is observed, the device should be replaced.

Receptacle contacts may be inspected by a qualified electrician. This should only be done with the power off. It is accomplished by depressing the numbered ring around the circumference of the interior on two opposite points. This will allow the shutter to be manually turned clockwise as required to permit access to the contacts. Once the inspection is complete, the shutter **must** be rotated counter-clockwise until it is locked in the closed position.

MANUFACTURER'S RESPONSIBILITY

Meltric's responsibility is strictly limited to the repair or replacement of any product that does not conform to the warranty specified in the purchase contract. Meltric shall not be liable for any penalties or consequential damages associated with the loss of production, work, profit or any financial loss incurred by the customer.

Meltric Corporation shall not be held liable when its products are used in conjunction with products not bearing the **Milarecha**™ Quality Label. The use of Meltric products in conjunction with mating devices that are not marked with the **Milarecha**™ Quality Label shall void all warranties on the product.

Meltric Corporation is an ISO 9001 certified company. Its products are designed, manufactured and rated in accordance with applicable UL, CSA and IEC standards. Meltric is also a member of BECMA, the international Butt-contact Electrical Connectors Manufacturers' Association. Like all members, Meltric additionally designs and manufactures its products in accordance with BECMA standards established to ensure intermatibility with similarly rated products manufactured by other members.



www.becma.ch